

RACAL INSTRUMENTS 1260-120 20 CHANNEL PLUG-IN

PUBLICATION NO. 980824-120

EADS North America Defense Test and Services, Inc.
4 Goodyear, Irvine, CA 92618
Tel: (800) 722-2528, (949) 859-8999; Fax: (949) 859-7139

info@eads-nadefense.com
sales@eads-nadefense.com
helpdesk@eads-nadefense.com
<http://www.eads-nadefense.com>



PUBLICATION DATE: October 28, 2003

Copyright 1998 by EADS North America Defense Test and Services, Inc. Printed in the United States of America. All rights reserved. This book or parts thereof may not be reproduced in any form without written permission of the publisher.

**THANK YOU FOR PURCHASING THIS
EADS NORTH AMERICA DEFENSE TEST AND SERVICES PRODUCT**

For this product, or any other EADS North America Defense Test and Services, Inc. product that incorporates software drivers, you may access our web site to verify and/or download the latest driver versions. The web address for driver downloads is:

<http://www.eads-nadefense.com/downloads>

If you have any questions about software driver downloads or our privacy policy, please contact us at:

info@eads-nadefense.com

WARRANTY STATEMENT

All EADS North America Defense Test and Services, Inc. products are designed and manufactured to exacting standards and in full conformance to EADS ISO 9001:2000 processes.

This warranty does not apply to defects resulting from any modification(s) of any product or part without EADS North America Defense Test and Services, Inc. express written consent, or misuse of any product or part. The warranty also does not apply to fuses, software, non-rechargeable batteries, damage from battery leakage, or problems arising from normal wear, such as mechanical relay life, or failure to follow instructions.

This warranty is in lieu of all other warranties, expressed or implied, including any implied warranty of merchantability or fitness for a particular use. The remedies provided herein are buyer's sole and exclusive remedies.

For the specific terms of your standard warranty, or optional extended warranty or service agreement, contact your EADS North America Defense Test and Services, Inc. customer service advisor. Please have the following information available to facilitate service.

1. Product serial number
2. Product model number
3. Your company and contact information

You may contact your customer service advisor by:

E-Mail:	Helpdesk@eads-nadefense.com	
Telephone:	+1 800 722 3262	(USA)
Fax:	+1 949 859 7309	(USA)

RETURN of PRODUCT

Authorization is required from EADS North America Defense Test and Services, Inc. before you send us your product for service or calibration. Call or contact the Customer Support Department at 1-800-722-3262 or 1-949-859-8999 or via fax at 1-949-859-7139. We can be reached at: helpdesk@eads-nadefense.com.

PROPRIETARY NOTICE

This document and the technical data herein disclosed, are proprietary to EADS North America Defense Test and Services, Inc., and shall not, without express written permission of EADS North America Defense Test and Services, Inc., be used, in whole or in part to solicit quotations from a competitive source or used for manufacture by anyone other than EADS North America Defense Test and Services, Inc. The information herein has been developed at private expense, and may only be used for operation and maintenance reference purposes or for purposes of engineering evaluation and incorporation into technical specifications and other documents which specify procurement of products from EADS North America Defense Test and Services, Inc.

DISCLAIMER

Buyer acknowledges and agrees that it is responsible for the operation of the goods purchased and should ensure that they are used properly and in accordance with this handbook and any other instructions provided by Seller. EADS North America Defense Test and Services, Inc. products are not specifically designed, manufactured or intended to be used as parts, assemblies or components in planning, construction, maintenance or operation of a nuclear facility, or in life support or safety critical applications in which the failure of the EADS North America Defense Test and Services, Inc. product could create a situation where personal injury or death could occur. Should Buyer purchase EADS North America Defense Test and Services, Inc. product for such unintended application, Buyer shall indemnify and hold EADS North America Defense Test and Services, Inc., its officers, employees, subsidiaries, affiliates and distributors harmless against all claims arising out of a claim for personal injury or death associated with such unintended use.

FOR YOUR SAFETY

Before undertaking any troubleshooting, maintenance or exploratory procedure, read carefully the **WARNINGS** and **CAUTION** notices.



CAUTION
RISK OF ELECTRICAL SHOCK
DO NOT OPEN



This equipment contains voltage hazardous to human life and safety, and is capable of inflicting personal injury.



If this instrument is to be powered from the AC line (mains) through an autotransformer, ensure the common connector is connected to the neutral (earth pole) of the power supply.



Before operating the unit, ensure the conductor (green wire) is connected to the ground (earth) conductor of the power outlet. Do not use a two-conductor extension cord or a three-prong/two-prong adapter. This will defeat the protective feature of the third conductor in the power cord.



Maintenance and calibration procedures sometimes call for operation of the unit with power applied and protective covers removed. Read the procedures and heed warnings to avoid “live” circuit points.

Before operating this instrument:

1. Ensure the proper fuse is in place for the power source to operate.
2. Ensure all other devices connected to or in proximity to this instrument are properly grounded or connected to the protective third-wire earth ground.

If the instrument:

- fails to operate satisfactorily
- shows visible damage
- has been stored under unfavorable conditions
- has sustained stress

Do not operate until, performance is checked by qualified personnel.

Racal Instruments

EC Declaration of Conformity

We

Racal Instruments Inc.
4 Goodyear Street
Irvine, CA 92718

declare under sole responsibility that the

**1260-120 Power Switch Plug In Module
P/N 407631**

conforms to the following Product Specifications:

Safety: EN 61010-1

EMC: EN50081-1
CISPR 11:1990/EN 55011 (1991): Group 1 Class A
IEC 801-2:1991/EN 50082-1 (1992): 4 kV CD, 8 kV AD
IEC 801-3:1984/EN 50082-1 (1992): 3 V/m, 27-500 MHz
IEC 801-4:1988/EN 50082-1 (1992): 1 kV

Supplementary Information:

The above specifications are met when the product is installed in a Racal Instruments Adapt-a-Switch Carrier with faceplates installed over all unused slots, as applicable. The carrier is installed in a certified mainframe.

The product herewith complies with the requirements of the Low Voltage Directive 73/23/EEC and the EMC Directive 89/336/EEC.

Irvine, CA, November 12, 1998

Quality Manager

This page was left intentionally blank.

Table of Contents

Chapter 1 1-1

SPECIFICATIONS 1-1

 Introduction..... 1-1

 Specifications 1-2

 Power Dissipation..... 1-3

 About MTBF 1-4

 Ordering Information 1-5

Chapter 2 2-1

INSTALLATION INSTRUCTIONS..... 2-1

 Unpacking and Inspection 2-1

 Reshipment Instructions 2-1

 Installation 2-1

 Module Configuration 2-2

 Front Panel Connectors..... 2-4

 Mating Connectors..... 2-6

 More About Maximum Current Ratings..... 2-8

 Installation 2-8

Chapter 3	3-1
MODULE OPERATION	3-1
Setting the Module Address	3-1
Operating Modes	3-2
Operating In Message-Based Mode	3-4
Channel Descriptors For The 1260-120	3-4
Reply To The MOD:LIST? Command	3-5
Operating The 1260-120 in Register-Based Mode	3-5
1260-120 Example Code	3-8
Emergency Reset	3-10
Connecting the Safety Switch	3-10
Normally-Open and Normally-Closed Switches	3-11
Local and Global Reset Options	3-12
Momentary vs. Latching Switches	3-13
Chapter 4	4-1
OPTIONAL HARNESS ASSEMBLIES	4-1
Chapter 5	5-1
PRODUCT SUPPORT	5-1
Product Support	5-1
Warranty	5-1

List of Figures

Figure 1-1, The 1260-120 1-1

Figure 2-1, 1260-120 Block Diagram 2-3

Figure 2-2, Front Panel Connector Pin Numbering..... 2-4

Figure 3-1, Message-Based Mode of Operation 3-3

Figure 3-2, Register-Based Mode of Operation 3-3

Figure 3-3, JP6 Configuration Jumper 3-11

Figure 3-4, JP7 Configuration Jumper 3-12

List of Tables

Table 2-1, 1260-120 Front-Panel Connections 2-5

Table 2-2, Mating Connectors and Pins..... 2-7

Table 3-1, Control Register Channel Assignments 3-6

This page was left intentionally blank.

Chapter 1

SPECIFICATIONS

Introduction

The 1260-120 is a plug-in switch module developed for the 1260-100 Adapt-a-Switch Carrier. The 1260-120 includes the following features:

- Standard Adapt-a-Switch plug-in design, providing for ease of replacement.
- Data-Driven embedded descriptor, allowing immediate use with any Option-01T switch controller, regardless of firmware revision level.

The 1260-120 is a 20-channel single-wire switch consisting of 20 individual SPST relay switches. The 1260-120 plug-in fits into a 1260-100 Adapt-a-Switch Carrier.

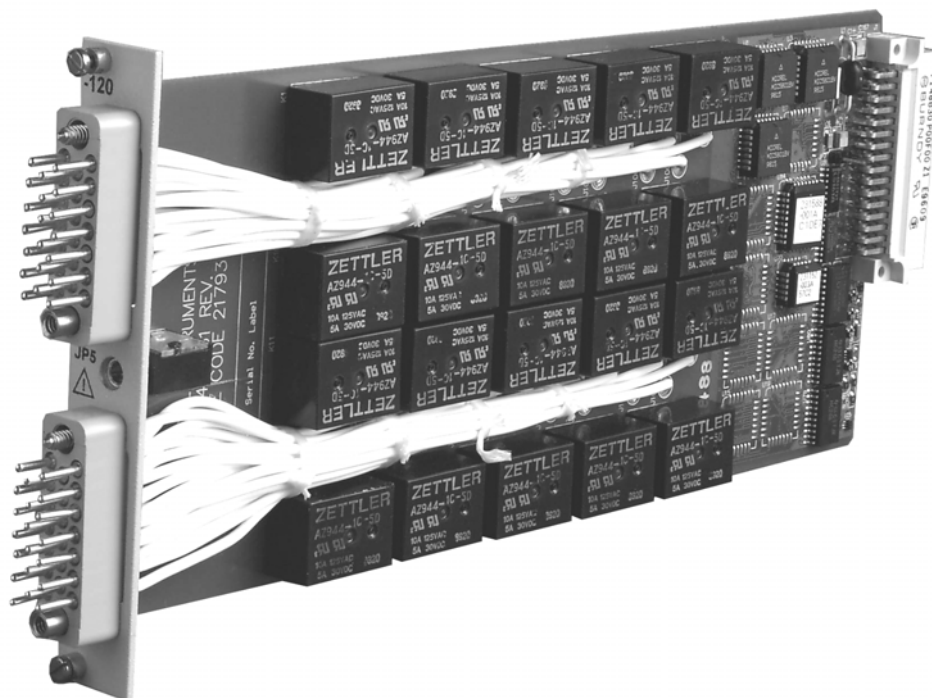

Figure 1-1, The 1260-120

Specifications

Bandwidth (-3dB)	Small signal: 50 MHz Power: 400 Hz
Insertion Loss 1 KHz	< -3 dB
Return Loss	20 dB to 1 MHz
Isolation 1 KHz	> 100 dB
Crosstalk 1 KHz	< -100 dB
Switching Voltage AC DC	250 V, Max 125 V, Max
Switching Current AC DC	13 A, Max. (see the mating connectors paragraph in Chapter 2) 10 A, Max
Switching Power AC DC	2000 VA, Max 300 W, Max
Path resistance	< 200 m Ω (Measured by voltage drop, 6 VDC, 1A)
Thermal EMF	< 50 uV
Capacitance Channel-Chassis Open-Channel	< 10 pF < 200 pF
Insulation resistance	> 10 ⁹ Ω
Relay Settling Time	< 10 ms
Shock	30 g, 11 ms, 1/2 sine wave
Vibration	0.013 in. P-P, 5-55 Hz
Bench Handling	4 in., 45°
Cooling	See 1260-100 cooling data
Temperature Operating Non-operating	0°C to +55°C -40°C to +75°C

Relative Humidity	85%, non-condensing at < 30°C
Altitude	
Operating	10,000 feet
Non-operating	15,000 feet
Power Requirements	
+5 VDC	150mA + 40mA per energized relay (1A Max.)
Weight	13 oz. (0.45 kg)
MTBF	979,058 hours (MIL-HDBK-217E)
Relay Life Expectancy	
Mechanical	10,000,000 operations
Electrical	100,000 operations at full load
Dimensions	4.5"H X 0.75"W X 9.5"D

Power Dissipation

While the cooling of the Adapt-a-Switch carrier is dependent upon the chassis into which it is installed, the carrier can normally dissipate approximately 100 W. Care must be taken, then, in the selection and loading of the plug-in modules used in the carrier. It is not possible to fully load the carrier, energize every relay, and run full power through every set of contacts, all at the same time. In practice this situation would never occur.

To properly evaluate the power dissipation of the plug-in modules, examine the path resistance, the current passing through the relay contacts, the ambient temperature, and the number of relays closed at any one time.

For example, if a 1260-118 module (containing 80 relays) has 25 relays closed, passing a current of 0.5 A, then:

$$\text{Total power dissipation} = [(\text{current})^2 * (\text{path resistance}) * 25] + (\text{quiescent power})$$

By substituting the actual values:

$$\text{Total power dissipation} = [(0.5 \text{ A})^2 * (1 \ \Omega) * 25] + (0.75 \text{ W}) = 7 \text{ W at } 55^\circ\text{C}$$

This is acceptable power dissipation for an individual plug-in module. If five additional modules are likewise loaded, then the overall carrier dissipation is approximately 36 W, which is well within the cooling available in any commercial VXIbus chassis. In practice, rarely are more than 25% of the module's relays energized simultaneously, and rarely is full rated current run

through every path. In addition, the actual contact resistance is typically one-half to one-fourth the specified maximum, and temperatures are normally not at the rated maximum. The power dissipated by each plug-in should be no more than 15 W if all six slots are used simultaneously. This yields the following guideline:

0.5 A	Max. 56 relays closed
1.0 A	Max. 14 relays closed
2.0 A	Max. 4 relays closed

Most users of a signal-type switch, such as the 1260-118, switch no more than a few hundred milliamperes and are able to energize all relays simultaneously, should they so desire. The numbers in the above table represent worst-case, elevated-temperature, end-of-life conditions.

Additionally, if fewer plug-in modules are used, more power may be dissipated by the remaining cards. By using a chassis with high cooling capacity, such as the 1261B, almost any configuration may be realized.

About MTBF

The 1260-120 MTBF is 979,058 hours, calculated in accordance with MIL-HDBK-217E, with the exception of the electromechanical relays. Relays are excluded from this calculation because relay life is strongly dependent upon operating conditions. Factors affecting relay life expectancy are:

1. Switched voltage
2. Switched current
3. Switched power
4. Maximum switching capacity
5. Maximum rated carrying current
6. Load type (resistive, inductive, capacitive)
7. Switching repetition rate
8. Ambient temperature

The most important factor is the maximum switching capacity, which is an interrelationship of maximum switching power, maximum switching voltage and maximum switching current. When a relay operates at a lower percentage of its maximum switching capacity, its life expectancy is longer. The maximum switching capacity specification is based on a resistive load, and must be further de-rated for inductive and capacitive loads.

For more details about the above life expectancy factors, refer to the data sheet for the switch plug-in module.

The relay used on the 1260-120 plug-in is part no. 310265-001. The relay manufacturer's specifications for this relay are:

Life Expectancy	
Mechanical	5,000,000 operations
Electrical	500,000 operations at full rated load (resistive)

For additional relay specifications, refer to the relay manufacturer's data sheet.

Ordering Information

Listed below are part numbers for both the 1260-120 switch module and available mating connector accessories. Each 1260-120 uses a single mating connector.

ITEM	DESCRIPTION	PART #
1260-120 Switch Module	1260-120, 20 Channel SPST 10 A Consists of: 405131 PCB Assy 407653-120 Shipping Kit (mating connector, manual)	407631
20 Pin Mating Connector	20 Pin Conn. Kit w/backshell & pins	407660
Cable Assy. 6ft., Sleeved	20 Pin Cable Assy, 6 Ft, 14 AWG (2 Req'd)	407657
Additional Manual		980824-120

This page was left intentionally blank.

INSTALLATION INSTRUCTIONS

Unpacking and Inspection

1. Remove the 1260-120 module and inspect it for damage. If any damage is apparent, inform the carrier immediately. Retain shipping carton and packing material for the carrier's inspection.
2. Verify that the pieces in the package you received contain the correct 1260-120 module option and the 1260-120 Users Manual. Notify EADS North America Defense Test and Services, Inc. if the module appears damaged in any way. Do not attempt to install a damaged module into a VXI chassis.
3. The 1260-120 module is shipped in an anti-static bag to prevent electrostatic damage to the module. Do not remove the module from the anti-static bag unless it is in a static-controlled area.

Reshipment Instructions

1. Use the original packing when returning the switching module to EADS North America Defense Test and Services, Inc. for calibration or servicing. The original shipping carton and the instrument's plastic foam will provide the necessary support for safe reshipment.
2. If the original packing material is unavailable, wrap the switching module in an ESD Shielding bag and use plastic spray foam to surround and protect the instrument.
3. Reship in either the original or a new shipping carton.

Installation

Installation of the 1260-120 Switching Module into a 1260-100 Carrier assembly is described in the Installation section of the 1260-100 Adapt-a-Switch Carrier Manual.

Module Configuration

The 1260-120 is a 20-channel single-wire switch module consisting of twenty SPST relay switches. This architecture permits the 1260-120 module to be organized via software in any configuration from twenty SPST to one 20PST, or any combination in between, by use of the *Include* command, without the use of hardware jumpers. This is the same as a 1-wire, 2-wire, ..., n-wire switch.

In addition, by jumpering pins at the module connectors, the user can configure the module as a SP2T, SP3T, etc., up to a SP20T switch. This type of configuration is known as a multiplexer.

For a block diagram of the 1260-120, see **Figure 2-1**.

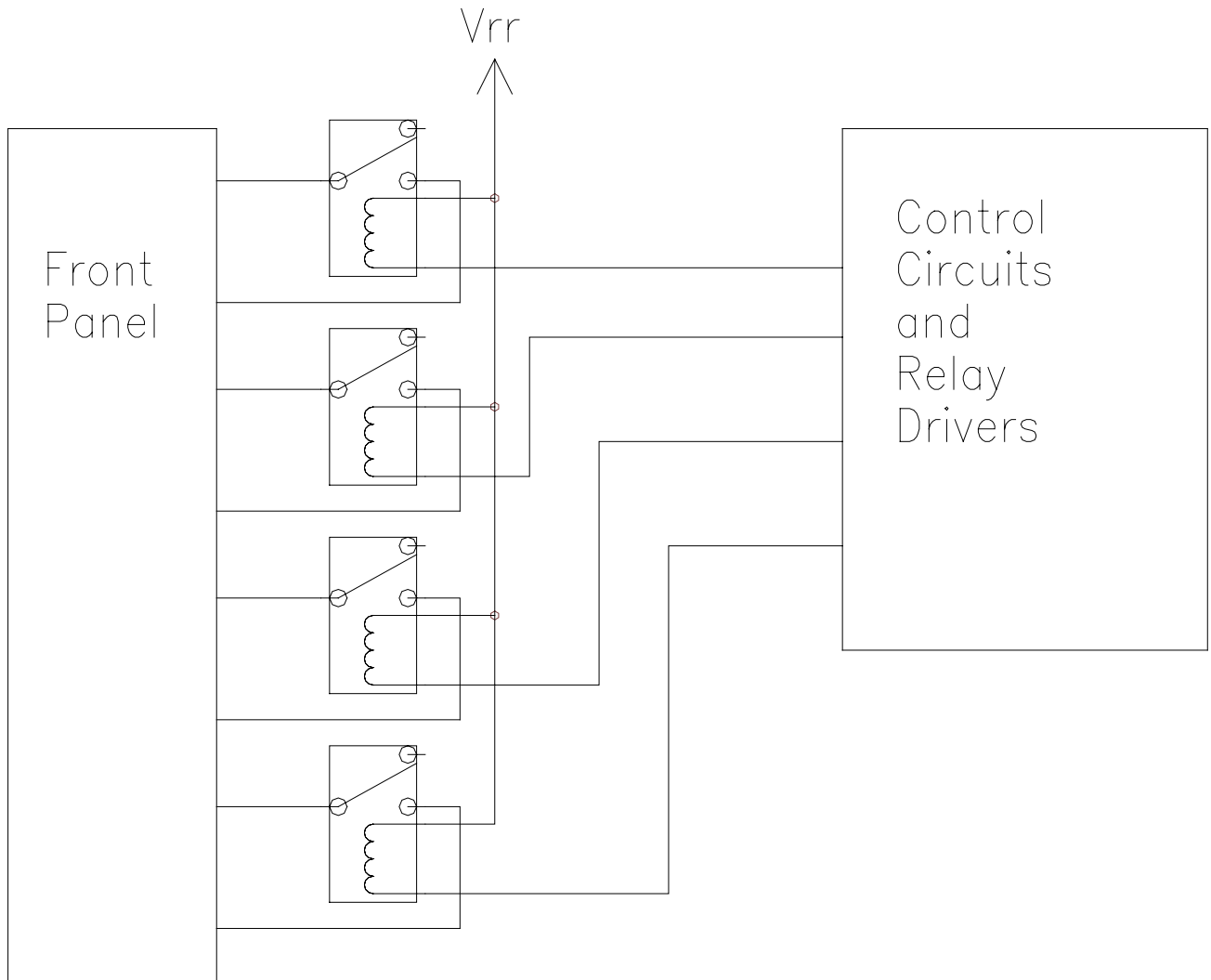

Figure 2-1, 1260-120 Block Diagram

Front Panel Connectors

The 1260-120 has two 21-pin front-panel connectors, labeled J200 and J202. It has one pin for each input and one for each output. See **Figure 2-2** for pin numbering. **Table 2-1** shows the mapping of channel numbers to connector pins. Information about available mating connectors is provided immediately after **Table 2-1**.

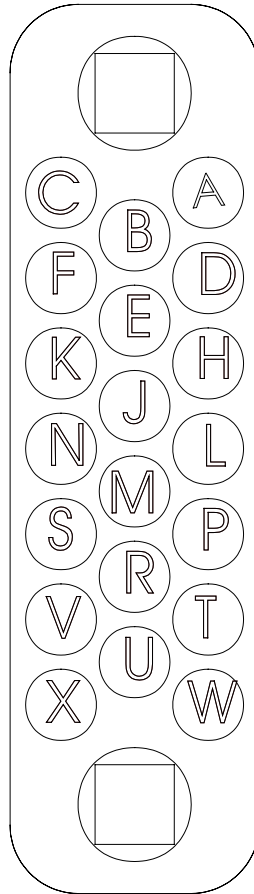

Figure 2-2, Front Panel Connector Pin Numbering

Table 2-1, 1260-120 Front-Panel Connections

Channel	Connector	Pin	Relay
0 In	J200	A	1
0 Out	J200	B	1
1 In	J200	C	2
1 Out	J200	D	2
2 In	J200	E	3
2 Out	J200	F	3
3 In	J200	H	4
3 Out	J200	J	4
4 In	J200	K	5
4 Out	J200	L	5
5 In	J200	M	6
5 Out	J200	N	6
6 In	J200	P	7
6 Out	J200	R	7
7 In	J200	S	8
7 Out	J200	T	8
8 In	J200	U	9
8 Out	J200	V	9
9 In	J200	W	10
9 Out	J200	X	10
10 In	J201	A	11
10 Out	J201	B	11
11 In	J201	C	12
11 Out	J201	D	12
12 In	J201	E	13
12 Out	J201	F	13
13 In	J201	H	14
13 Out	J201	J	14
14 In	J201	K	15
14 Out	J201	L	15
15 In	J201	M	16
15 Out	J201	N	16
16 In	J201	P	17
16 Out	J201	R	17
17 In	J201	S	18
17 Out	J201	T	18
18 In	J201	U	19
18 Out	J201	V	19
19 In	J201	W	20
19 Out	J201	X	20

Mating Connectors

Mating connector accessories are available:

20 Pin Connector Kit with backshell and pins
P/N 407660

20 Pin Cable Assembly, 6 Ft., 14 AWG
P/N 407657

The 20 pin connector kit consists of a connector housing, aluminum backshell, and twenty solder-cup pins.

After wire attachment, the pin is inserted in the housing and will snap into place, providing positive retention. To ensure that the pin is locked into place, the assembler should pull on the wire after insertion.

The 20-Pin Cable Assembly uses 14 AWG cable with solder-cup pins to mate with the 1260-120. The other cable end is un-terminated.

Refer to **Table 2-1** for channel-to-pin mapping information. **Table 2-2** shows additional mating connectors and pins.

Table 2-2, Mating Connectors and Pins

Part Number	Manufacturer	Mfr. P/N	Description
602349-120	Positronic	GMCT20F0E100J0	Insulator block (diallyl pthalate), 20-position. Mates with front-panel connector. Pins sold separately.
601850-900	Positronic	FC114N2	Female contact, crimp type, for 14 AWG wire. Mates with front-panel connector pins.
N/A	Positronic	FC116N2	Female contact, crimp type, for 16 AWG wire. Mates with front-panel connector pins.
N/A	Positronic	FS114N2	Female contact, solder type, for 14 AWG wire. Mates with front-panel connector pins.
N/A	Positronic	FS116N2	Female contact, solder type, for 16 AWG wire. Mates with front-panel connector pins.
602349-020	Burndy	MS20PM-58	Insulator block, 20-position. Part of front-panel connector assembly. Pins sold separately.
601851-900	Burndy	RM16M-31028	Male contact, 0.062" dia., crimp type, for 16 to 20 AWG wire. Part of front-panel connector assembly.

More About Maximum Current Ratings

The front panel connector and pins are rated for 13 A per pin, with all channels conducting full-rated current. This keeps the temperature rise within 10°C. If all channels are not used simultaneously, or if temperature rise is not a concern, then the current may be increased to 16 amperes AC (the relays are rated at 16 A). It should be noted that with all electromechanical relays, the higher the switched power (voltage times current), the shorter the useful life of the relays.

Definitions:

- *Max current carrying capacity*

The maximum current that the relay can conduct if the relay is not switched while voltage is applied. The maximum current carrying capacity is affected by the size of the conducting section of the contact at its smallest area. The listed values are obtained from several tests in laboratories under room-temperature conditions (21°C). The contact is considered to be in free air. The maximum current carrying for the 1260-120 is 22 A.

- *Max operating current*

The current the contacts can switch while conducting, without deteriorating. This depends on working conditions, such as dissipated heat, cooling provisions, ambient temperature, insulation material, etc. The maximum operating current for the 1260-120 is 13 A.

- *Recommended continuous current*

The maximum current recommended for indefinitely-long time periods. The primary concern here is the heat generated in the relay. This specification can be applied for normal working conditions. The specification includes a safety margin. However, there are restrictions in the application of the given values. The most important restriction is the cross-sectional area of the connecting wire, insulation temperature range, and wire bundling. The recommended continuous current for the 1260-120 is 10 A.

Installation

To install the 1260-120 Switching Module into a 1260-100 Carrier, engage the printed circuit board into the grooves of the desired carrier slot. Slide the 1260-120 into the carrier until its connector mates with the connector on the carrier backplane. Push firmly to fully seat the connector. Tighten the two retaining screws at the top and bottom of the 1260-120 plug-in.

Chapter 3

MODULE OPERATION

Setting the Module Address

The Option-01T switch controller identifies each Adapt-a-Switch plug-in or conventional 1260-Series module by a *module address* that is unique to that module. The module address is a number from 1 through 12, inclusive.

The module address assigned to the 1260-120 depends on the carrier slot into which the 1260-120 is inserted, and on the position of the logical address DIP switch on the carrier side panel. The switch has two settings:

- 1-6 (closed): When the switch is set to this position, the module addresses of the plug-ins in the 1260-100 Carrier are from 1 through 6. The module with address 1 is in the left slot of the top row. The plug-ins are addressed in the following pattern:

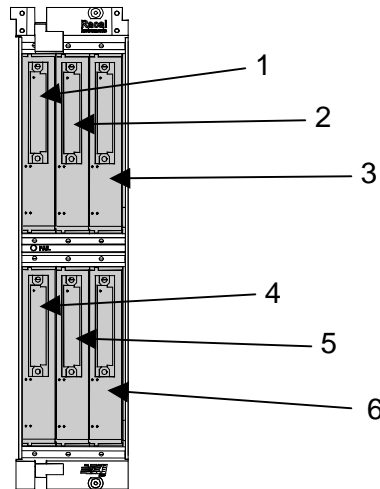

Front View – Module Addresses for 1 through 6

- 7 - 12 (open): When the switch is set to this position, the module addresses of the plug-ins in the 1260-100 Carrier are from 7 through 12, in the following pattern:

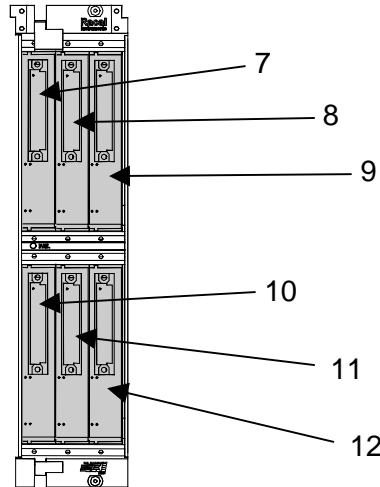

Front View – Module Addresses for 7 through 12

When setting module addresses for Adapt-a-Switch Carriers and conventional 1260-Series modules, be sure that no address is used by more than one plug-in or 1260-Series C-Size switching module.

For instructions on setting module addresses for a conventional 1260-Series module, see the label on the side panel of the module.

Operating Modes

The 1260-120 may be operated either in *message-based* mode or in *register-based* mode.

In the *message-based* mode, the 1260-01T switch controller interprets commands sent by the slot 0 controller, and determines the appropriate data to send to the control registers of the 1260-120 module.

A conceptual view of the message-based mode of operation is shown in **Figure 3-1** below.

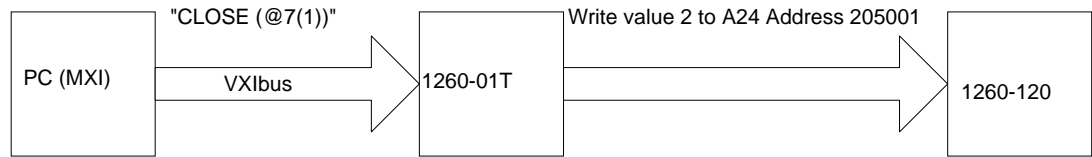

Figure 3-1, Message-Based Mode of Operation

In the *register-based* mode, the user writes directly to the control registers on the 1260-120 module. The 1260-01T command module does not monitor these operations, and does not keep track of the relay states on the 1260-120 module in this mode.

A conceptual view of the register-based mode is shown in **Figure 3-2** below.

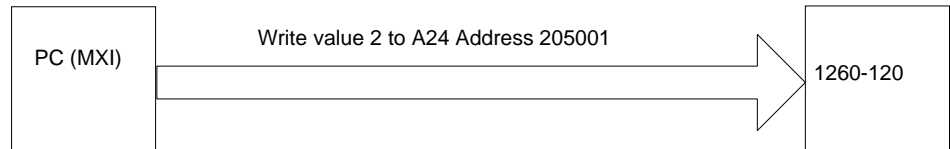

Figure 3-2, Register-Based Mode of Operation

Since the 1260-01T switch controller does not keep track of relay states during the register-based mode, it is advisable to use **either** the message-based or the register-based mode, and continue to use the same mode throughout the application program.

In general, the message-based mode of operation is easier to use with utility software such as the National Instruments VXI Interactive Control (VIC) program. The message-based mode allows the user to send ASCII text commands to the 1260-01T and to read replies from the 1260-01T. In addition, some features, such as the SCAN list, are available only in the message-based mode of operation.

The register-based mode provides faster control of relay channels. In this mode, relay operations are processed in less than 9 microseconds, not counting relay settling time or software overhead inherent in I/O libraries such as VISA. To determine the relay settling time, refer to Relay Settling Time in the Specifications section.

Consult the 1260-01T User's Manual for a comparison of the message-based and register-based modes of operation.

Operating In Message-Based Mode

Channel Descriptors For The 1260-120

The standard 1260-01T commands are used to operate the 1260-120 module. These commands are described in the 1260-01T User's Manual.

Each 1260-01T relay command uses a *channel descriptor* to select the channel(s) of interest. The syntax for a channel descriptor is the same for all 1260 series modules. In general, the following syntax is used to select a single channel:

```
(@ <module address> ( <channel> ) )
```

Where:

- <module address> is the address of the 1260-120 module. This is a number in the range from 1 through 12, inclusive.
- <channel> is the 1260-120 channel to operate. This is a number in the range from 0 through 19, inclusive.

Multiple individual channels may be specified using the following channel descriptor syntax:

```
@ <module address> ( <chan1> , <chan2>  
 , . . . , <chanN> ) )
```

A range of channels may be specified using the following channel descriptor syntax:

```
@ <module address> ( <first channel> :  
<last channel> ) )
```

The following examples illustrate the use of the channel descriptors for the 1260-120:

OPEN (@8(0))	Open channel 0 on the 1260-120 that has module address 8.
CLOSE (@8(0,7))	Close channels 0 and 7 on the 1260-120 that has module address 8.
CLOSE (@2(7:12))	Close channels 7 through 12, inclusive, on the 1260-120 that has module address 2.

Reply To The MOD:LIST? Command

The 1260-01T returns a reply to the MOD:LIST? command. This reply is unique for each different 1260 series switch module. The syntax for the reply is:

<module address> : <module-specific identification string>

The <module-specific identification string> for the 1260-120 is:

1260-120 20-CHANNEL SPST 10A SWITCH MODULE

So, for a 1260-120 whose <module address> is set to 8, the reply to this query would be:

8 : 1260-120 20-CHANNEL SPST 10A SWITCH
MODULE

Operating The 1260-120 in Register-Based Mode

In register-based mode, the 1260-120 is operated by directly writing and reading control registers on the 1260-120 module. The first control register on the module operates channels 0 through 7. The second control register operates channels 8 through 15. The third control register operates channels 16 through 19. When a control register is written to, all channels controlled by that register are operated simultaneously.

The control registers are located in the VXIbus A24 Address Space. The A24 address for a control register depends on:

1. The A24 Address Offset assigned to the 1260-01T module by the Resource Manager program. The Resource Manager program is provided by the VXIbus slot-0 controller vendor. The A24 Address Offset is placed into the "Offset Register" of the 1260-01T by the Resource Manager.
2. The <module address> of the 1260-120 module. This is a value in the range from 1 and 12 inclusive.
3. The 1260-120 control register to be written to or read from. Each control register on the 1260-120 has a unique address.

The base A24 address for the 1260-120 module may be calculated by:

(A24 Offset of Option-01T) + (1024 x Module Address of 1260-120).

The A24 address offset is usually expressed in hexadecimal. A typical value of 204000_{16} is used in the examples that follow.

A 1260-120 with a module address of 7 would have the base A24 address computed as follows:

$$\begin{aligned} \text{Base A24 Address of 1260-120} &= 204000_{16} + (400_{16} \times 7_{10}) \\ &= 205C00_{16} \end{aligned}$$

The control registers for Adapt-a-Switch plug-ins and conventional 1260-Series modules are always on odd-numbered A24 addresses. The three control registers for the 1260-120 reside at the first three odd-numbered A24 addresses for the module:

$$(\text{Base A24 Address of 1260-120}) + 1 = \text{Control Register 0}$$

$$(\text{Base A24 Address of 1260-120}) + 3 = \text{Control Register 1}$$

$$(\text{Base A24 Address of 1260-120}) + 5 = \text{Control Register 2}$$

So, for our example, the three control registers are located at:

- 205C01 Control Register 0, controls channels 0 through 7
- 205C03 Control Register 1, controls channels 8 through 15
- 205C05 Control Register 2, controls channels 16 through 19.

Table 3-1 shows the channel assignments for each control register.

Table 3-1, Control Register Channel Assignments

Control Register	Channels							
	Bit 7 (MSB)	Bit 6	Bit 5	Bit 4	Bit 3	Bit 2	Bit 1	Bit 0 (LSB)
0	7	6	5	4	3	2	1	0
1	15	14	13	12	11	10	9	8
2	23	22	21	20	19	18	17	16

Setting a control bit to 1 closes the corresponding channel, and clearing the bit to zero opens the corresponding channel. Thus, if you write the value 1000 0101 binary = 133 decimal = 85 hexadecimal to Control Register 0, channels 0, 2, and 7 will close, while channels 1, 3, 4, 5, and 6 will open.

The present control register value may be read back by reading an 8-bit value from the control register address. **The value is inverted.** In other words, the eight-bit value read back is the one's complement of the value written.

If you want to change the state of a single relay without affecting the present state of the other relays controlled by the control register, you must:

1. Read the control register.
2. Invert the bits (perform a one's complement on the register data).
3. Perform a bit-wise AND operation, leaving all but the specific control register bit for the relay to change.
4. **To open:** continue to step 5. **To close:** OR in the bit for the relay to close.
5. Write the modified value back to the control register.

For example, to close channel 13:

1. Read Control Register 1 (this register controls channels 8 through 15, with channel 8 represented by the LSB).
2. Invert the bits in the value read in step 1.
3. AND with 1101 1111 binary (the zero is in the position corresponding to channel 13).
4. OR with 0010 0000 binary.
5. Write the value to Control Register 1.

The VISA I/O library may be used to control the module. The VISA function `viOut8()` is used to write a single 8-bit byte to a control register, while `viIn8()` is used to read a single 8-bit byte from the control register. The following code example shows the use of `viOut8()` to update the 1260-120 module.

1260-120 Example Code

```
#include <visa.h>

/* This example shows a 1260-01T at logical address 16 and a VXI/MXI */
/* interface */
#define RI1260_01_DESC      "VXI::16"

/* For a GPIB-VXI interface, and a logical address of 77 */
/* the descriptor would be: "GPIB-VXI::77" */

/* this example shows a 1260-120 with module address 7 */
#define MOD_ADDR_120      7

void example_operate_1260_120(void)
{
    ViUInt8 creg_val;
    ViBusAddress creg0_addr;
    ViBusAddress creg1_addr;
    ViBusAddress creg2_addr;
    ViSession hdl1260;    /* VISA handle to the 1260-01T */
    ViSession hdlRM;      /* VISA handle to the resource manager */
    ViStatus error;      /* VISA error code */

    /* open the resource manager */
    /* this must be done once in application program */
    error = viOpenDefaultRM (&hdlRM);

    if (error < 0) {
        /* error handling code goes here */
    }

    /* get a handle for the 1260-01T */
    error = viOpen (hdlRM, RI1260_01_DESC, VI_NULL,VI_NULL, &hdl1260);
    if (error < 0) {
        /* error handling code goes here */
    }

    /* form the offset for control register 0 */
    /* note that the base A24 Address for the 1260-01T */
    /* is already accounted for by VISA calls viIn8() and */

```



```
/* viOut8() */

/* module address shifted 10 places = module address x 1024 */
creg0_addr = (MOD_ADDR_120 << 10) + 1;
creg1_addr = creg0_addr + 2;
creg2_addr = creg1_addr + 2;

/* close channel 13 without affecting the state of */
/* channels 8, 9, 10, 11, 12, 14, and 15 */
error = viIn8 (hdl1260, VI_A24_SPACE, creg1_addr, &creg_val);
if (error < 0) {
    /* error handling code goes here */
}

/* invert the bits to get the present control register value */
creg_val = ~creg_val;

/* AND to leave every channel except 13 unchanged */
creg_val &= ~ (0x20);

/* OR in the bit to close channel 13 */
creg_val |= 0x20;

/* write the updated control register value */
error = viOut8 (hdl1260, VI_A24_SPACE, creg1_addr, creg_val);
if (error < 0) {
    /* error handling code goes here */
}

/* open channel 16 without affecting channels 17 through 19 */
error = viIn8 (hdl1260, VI_A24_SPACE, creg2_addr, &creg_val);
if (error < 0) {
    /* error handling code goes here */
}

/* invert the bits to get the present control register value */
creg_val = ~creg_val;

/* AND to leave every channel except 16 unchanged */
/* leave bit 0 clear to open channel 16 */
creg_val &= ~ (0x01);

/* write the updated control register value */
error = viOut8 (hdl1260, VI_A24_SPACE, creg2_addr, creg_val);
if (error < 0) {
    /* error handling code goes here */
}
}
```

```
/* close the VISA session */  
error = viClose( hdl1260 );  
if (error < 0) {  
    /* error handling code goes here */  
}  
}
```

Emergency Reset

The Emergency Reset Feature provides a simple, reliable mechanism to open all relays quickly. This helps the system integrator maximize safety in a system that performs high-current switching.

The 1260-120 provides a connection for an emergency safety switch. The user provides the switch, and may mount it wherever desired so that it is easily and quickly accessible.

When the emergency reset switch is activated, the relays are immediately opened by hardware action alone. No software or firmware intervention is required. Even if the host computer or switch controller fails, the emergency reset function is still effective.

After the relays open in response to the emergency reset switch, they do not automatically return to their previous states when the switch is deactivated. The relays remain open until the user issues a command to close them.

Connecting the Safety Switch

Use a general-purpose mechanical switch. It need not have a high voltage or current rating. The signal passing through the switch is TTL compatible, and has a magnitude of 5 volts and a current of 0.5mA. The switch may be either normally-open or normally-closed.

To connect the switch to the 1260-120, use a standard miniature (IEC 3.5mm diameter) phone plug. Connect one side of the switch to the phone plug tip, and the other side to the phone plug sleeve. Insert the phone plug into the jack in the 1260-120 front panel.

Normally-Open and Normally-Closed Switches

The 1260-120 can work with either a normally-open or normally-closed switch. In the normally-open configuration, the 1260-120 detects an emergency reset when the switch is closed for more than 500ns. The normally-open configuration is the factory default. To verify that the 1260-120 is configured for a normally-open switch, ensure that no jumper or resistor is installed across the two pads comprising JP6 on the PCB (See **Figure 3-3, JP6 Configuration Jumper**).

In the normally-closed configuration, the 1260-120 detects an emergency reset condition when the switch contacts are opened for more than 500ns. To configure the 1260-120 for normally-closed operation (normally-closed switch), install a jumper across the two pads comprising JP6 on the 1260-120 printed circuit board (See **Figure 3-3, JP6 Configuration Jumper**). If possible, use a zero-ohm surface-mount resistor in the standard 0805 outline package. If such a resistor is not available, you may carefully solder a short piece of bare, solid, 28AWG wire across the two pads of JP6. Ensure that the wire does not contact any circuitry other than these two pads.

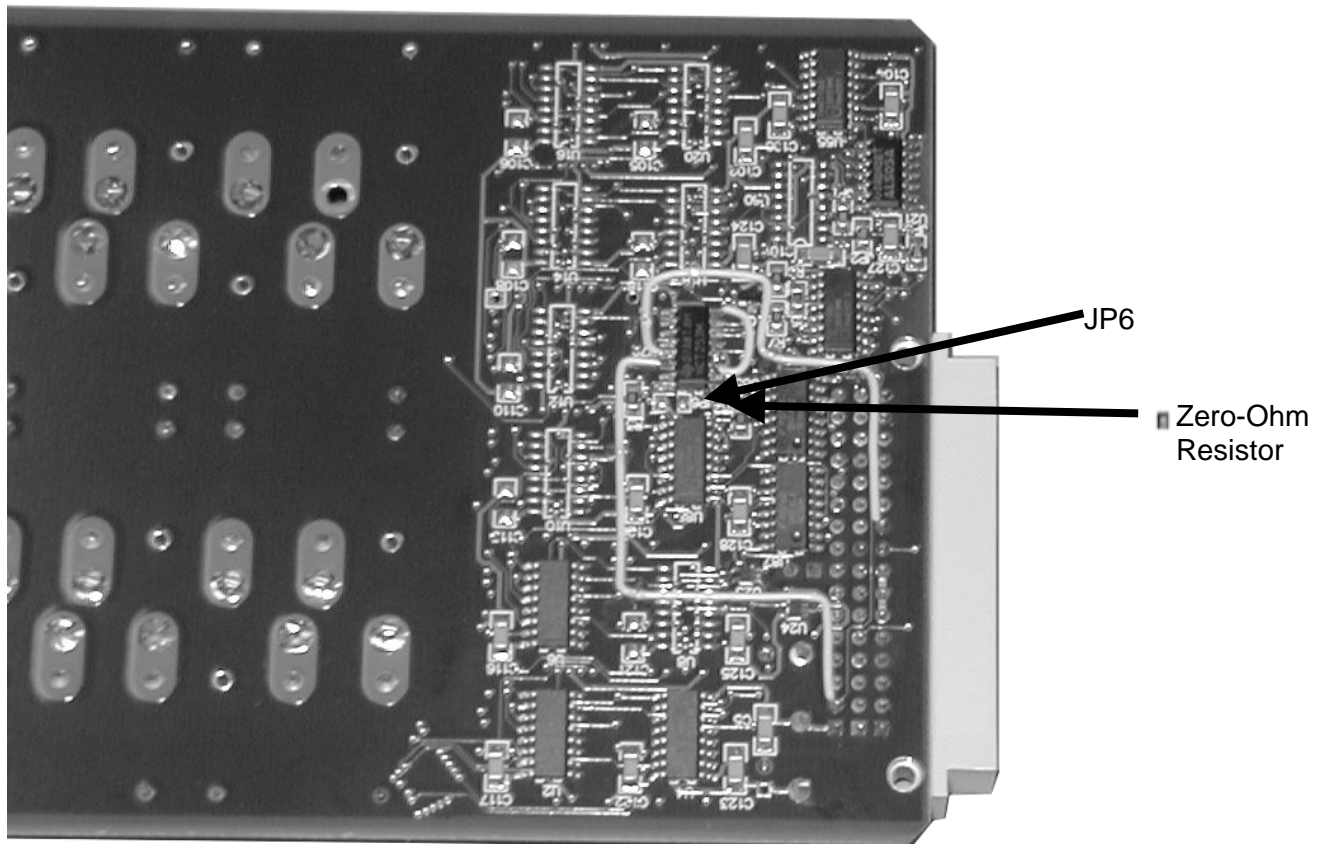

Figure 3-3, JP6 Configuration Jumper

Local and Global Reset Options

The scope of the reset can be set to either local or global. With a global reset, an emergency reset detected by one switch module will reset ALL other switch modules that are connected to the same controller (e.g. Option-01T Controller or 1256 Switching System). To configure the 1260-120 for the global reset option, install a jumper across the two pins comprising JP7 on the PCB (See **Figure 3-4, JP7 Configuration Jumper**).

If the 1260-120 is configured for the local reset option (the factory default), the emergency reset switch will affect only the module to which it is connected. All relays of that module will open when the switch is activated. Relays on other switch modules remain unaffected. The local reset option is configured by not installing a jumper at JP7 on the PCB (See **Figure 3-4, JP7 Configuration Jumper**).

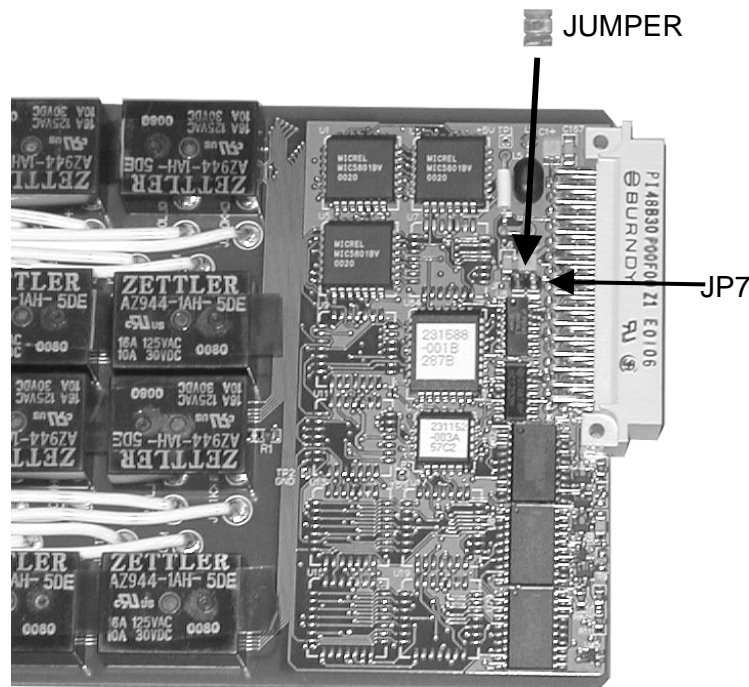

Figure 3-4, JP7 Configuration Jumper

Momentary vs. Latching Switches

Latching switches, also referred to as toggle switches, remain in one position (open or closed) until deliberately set to the other position. Momentary switches, on the other hand, change positions when activated, then return automatically to the normal position when released. Either type of switch may be used as a safety switch, depending upon the desired result.

A latching (toggle) switch, when activated, causes all relays to open. It also prevents any closure of relays until the switch is manually returned to its normal position. The switch modules ignore any commands sent to them while the switch is activated.

A momentary switch, when activated, also causes all relays to open. However, the switch returns to its normal position when released, and relay operations can then resume. Although the relays do not automatically return to their previous states when the switch is released, they resume normal operation, and respond to all commands.

A latching (toggle) switch provides the maximum safety by not only opening the relays, but preventing them from being closed again until the safety switch is manually returned to the normal position.

This page was left intentionally blank.

Chapter 4

OPTIONAL HARNESS ASSEMBLIES

407660	Connector Kit,	4-3
407657	Cable Assy,	4-4

This page was left intentionally blank.

1260-120 User Manual

EADS North America Defense Test and Services, INC.

Assembly 407660

20 PIN Conn. Kit W/BACKSHELL Rev Date 7/14/98 Revision A

#	Component	Description	U/M	Qty Reqd.	REF
1	602349-120	CON-CAB-RCP020-.-T	-E EA	1.000	
2	602349-900	CONTACT, SOLDER, FEMALE, 14AWG	-E EA	20.000	

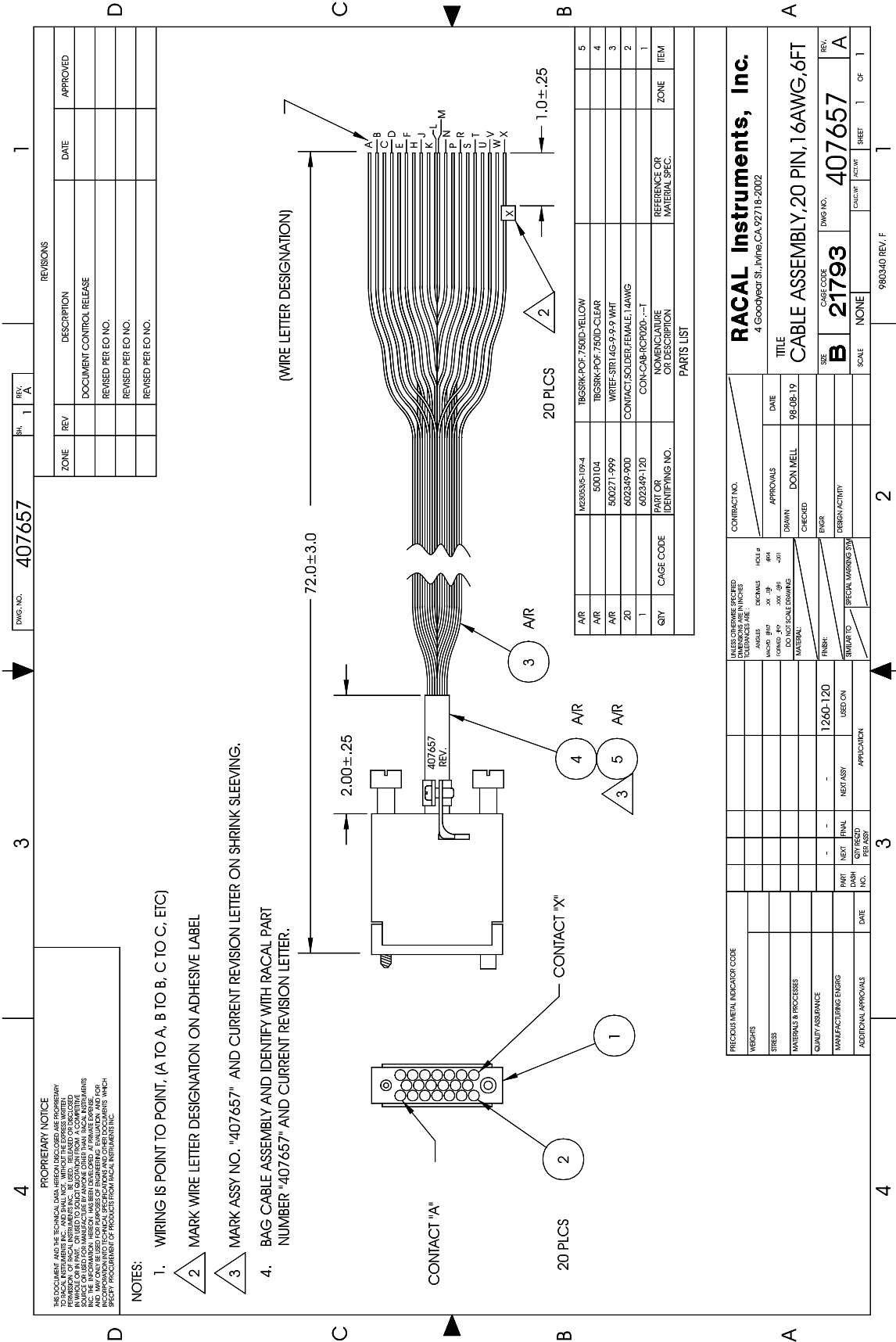

ZONE	REV	DESCRIPTION	DATE	APPROVED
		DOCUMENT CONTROL RELEASE		
		REVISED PER EO NO.		
		REVISED PER EO NO.		
		REVISED PER EO NO.		

REV	DATE	DESCRIPTION
1		

REV	DATE	DESCRIPTION
1		

- NOTES:
1. WIRING IS POINT TO POINT, (A TO A, B TO B, C TO C, ETC)
 2. MARK WIRE LETTER DESIGNATION ON ADHESIVE LABEL
 3. MARK ASSY NO. "407657" AND CURRENT REVISION LETTER ON SHRINK SLEEVING.
 4. BAG CABLE ASSEMBLY AND IDENTIFY WITH RACAL PART NUMBER "407657" AND CURRENT REVISION LETTER.

PRECISION METAL INDICATOR CODE		CONTRACT NO.		RACAL Instruments, Inc.	
WEIGHTS				4 Goodyear St., Irvine, CA 92718-2002	
STRESS				TITLE	
MATERIALS & PROCESSES				CABLE ASSEMBLY, 20 PIN, 16AWG, 6FT	
QUALITY ASSURANCE				TYPE	B
MANUFACTURING ENG'G				CAGE CODE	21793
ADDITIONAL APPROVALS				DWG NO.	407657
				SCALE	NONE
				CALC. BY	
				SHEET	1 OF 1

Chapter 5

PRODUCT SUPPORT

Product Support

EADS North America Defense Test and Services, Inc. has a complete Service and Parts Department. If you need technical assistance or should it be necessary to return your product for repair or calibration, call 1-800-722-3262. If parts are required to repair the product at your facility, call 1-949-859-8999 and ask for the Parts Department.

When sending your instrument in for repair, complete the form in the back of this manual.

For worldwide support and the office closest to your facility, refer to the website for the most complete information <http://www.eads-nadefense.com>.

Warranty

Use the original packing material when returning the 1260-120 to EADS North America Defense Test and Services, Inc. for calibration or servicing. The original shipping container and associated packaging material will provide the necessary protection for safe reshipment.

If the original packing material is unavailable, contact EADS North America Defense Test and Services, Inc. Customer Service at 1-800-722-3262 for information.

REPAIR AND CALIBRATION REQUEST FORM

To allow us to better understand your repair requests, we suggest you use the following outline when calling and include a copy with your instrument to be sent to the EADS North America Defense Test and Service, Inc. Repair Facility.

Model _____ Serial No. _____ Date _____

Company Name _____ Purchase Order # _____

Billing Address _____

City

State/Province

Zip/Postal Code

Country

Shipping Address _____

City

State/Province

Zip/Postal Code

Country

Technical Contact _____ Phone Number () _____

Purchasing Contact _____ Phone Number () _____

1. Describe, in detail, the problem and symptoms you are having. Please include all set up details, such as input/output levels, frequencies, waveform details, etc.

2. If problem is occurring when unit is in remote, please list the program strings used and the controller type.

3. Please give any additional information you feel would be beneficial in facilitating a faster repair time (i.e., modifications, etc.)

4. Is calibration data required? Yes No (please circle one)

Call before shipping
Note: We do not accept
"collect" shipments.

Ship instruments to nearest support office.